

IRROMETER[®]

1425 PALMYRITA AVE

RIVERSIDE, CA 92507

P: 951.682.9505

E: TECHSUPPORT@IRROMETER.COM

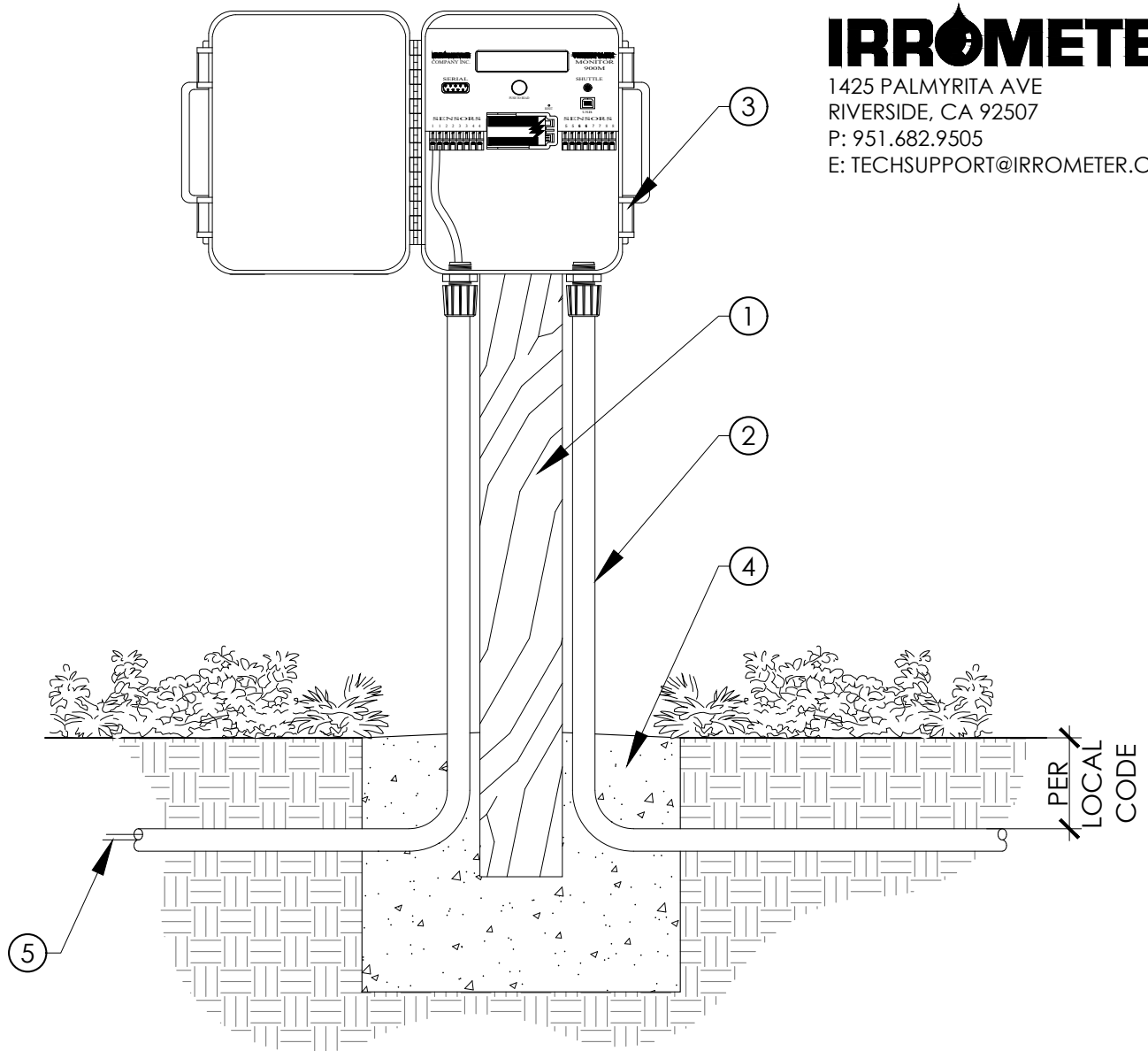

① MOUNTING POST. MINIMUM 4" X 4" TREATED WOOD.

② 3/4" CONDUIT SWEEP ELL

③ WATERMARK FIELD MONITOR.

④ CONCRETE POST ANCHOR MINIMUM 12" x 12" x 12" WITH POST INSERTED OR INSTALLED WITH GALVANIZED POST BASE

⑤ WIRE LEADS TO SENSOR. REPEAT FOR EACH SENSOR. REFER TO WATERMARK MONITOR FIELD MOISTURE SENSOR DETAIL

NOTES:

- LOCATE IN FIELD NEAR SENSORS MOUNTED ON POST AS SHOWN OR IN CONTROLLER ENCLOSURE.

NO SCALE

WATERMARK MONITOR FIELD INSTALLATION