

IRRIGROMETER CO.

...simple tools for optimizing irrigation, worldwide.

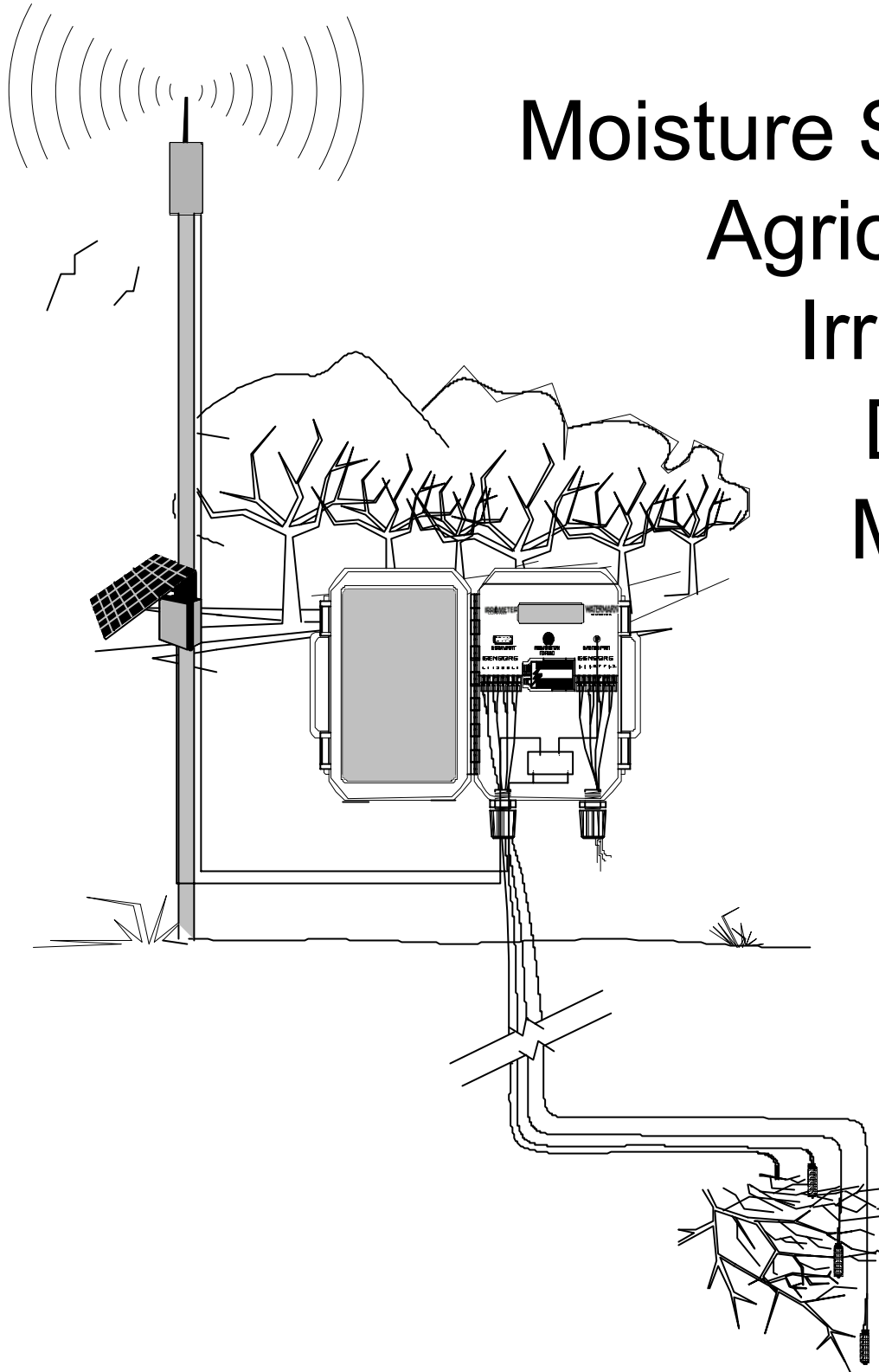

Moisture Sensor Agricultural Irrigation Design Manual

FOREWARD

Since 1951 Irrrometer Company, Inc. has been providing simple tools that help to answer the age old questions:

WHEN should I irrigate (How Often)

and

How long should I irrigate? (Cycle run time)

The need for knowing how to answer these two questions is even more important today than it was in 1951. World experts agree that water will be the limiting factor in World Food Production. Not land, not technology, but *WATER*.

Many moisture sensing products have come and gone over the years but Irrrometer Company, Inc. continues to be synonymous with quality, high value products.

This manual will introduce you to some of our products. We also show typical applications and illustrate how they can be specified. This manual does not show every application but feel free to call us to discuss your particular project needs.

For more information:

Phone: (951) 682-9505
Fax: (951) 682-9501
E-mail: sales@irrometer.com
Website: www.irrometer.com

Information contained in this manual is based on generally accepted information and practices. If any problems, difficulties, or injury arise from or in conjunction with the use of this information, or if there is any error herein, typographical or otherwise, Irrrometer Company, Inc., and its agents or employees thereof, shall not be responsible or liable therefore.

Contents

Introduction	3
Irrrometer information	4
Watermark information	5
Instrument selection guidelines	6
Irrrometers in orchards and row crop drawings	7
Irrrometer in vines drawings	8
Watermarks in orchard and row crop drawings	9
Watermarks in vines drawings	10
Sensors in center pivot drawing	11
Irrrometers in greenhouse drawing	11
Miscellaneous detail drawings	12
Watermark Monitor drawings	13
Soil Solution Access Tubes	14
Pressure Gauges	15
Detail drawings in AutoCAD (.dwg format) on a CD	

INTRODUCTION

Irrigation scheduling, A practical background

Since the dawn of mankind, irrigation has enhanced crop production. History records the benefits of irrigation, as well as the dismal failures caused by irrigation mismanagement. Today we are faced with dwindling water supplies, loss of water resources from pollution and permanent damage to land resources, in many cases due to mismanaging our most precious resource – water. “Water Conservation” is becoming the principal objective – often simply stated to the detriment of irrigated agriculture and landscapes. But the real “truth” of using irrigation wisely is simple – good agronomy. When irrigation is managed correctly, soil moisture

is maintained in an optimum condition for the creation of the best possible crop/plant health. Production can be maximized. Quality can be enhanced. Pests and disease are mitigated. Nutrients are efficiently utilized and not wasted. Energy is conserved, and, usually water use is decreased. The elimination of excessive irrigation also protects our water quality.

Soil moisture measurement has been proven for almost eight decades to be a very important and productive tool for managing and scheduling irrigation. The principal tools, consistently used throughout these years, are tensiometers (Irrrometers) and electrical resistance blocks (Watermarks). These simple, inexpensive, easy to use yet scientific devices allow an irrigation manager to “read” his soil moisture and to manage the irrigation system to produce the correct answer to the only important questions that occur:

WHEN to irrigate HOW MUCH to apply

Based on your sensor “reading” you can determine when you need to “Refill” your soil moisture reservoir (irrigate) and from experience to verify that your irrigation amount (or rainfall) indeed restored your soil to “Field Capacity”. Simply stated, Field Capacity is that condition which exists when the soil has been fully wetted by irrigation or rainfall, drainage has ceased and the soil water reservoir is storing as much water as it can hold. It’s nature’s balance of soil, water and air.

What the irrigation manager needs to do to use this technology is to install the Irrrometers and/or Watermarks in key locations throughout the fields and to “read” them 2 – 3 times between irrigations. The readings will tell you how fast the crop is extracting water (how fast the soil is drying out) and warn you in advance of needed irrigations.

- Produce better yield and quality
- Optimize production
- Reduce water waste
- Manage energy efficiently
- Maximize nutrient use
- Mitigate excessive runoff and deep percolation loss
- Help protect water quality

In short, more money in the bank at harvest.

Irrrometer Soil Moisture Sensors

Manual Irrrometers

Model R



Reading the vacuum gauge gives soil moisture tension at the placement depth. Standard lengths are 6", 12", 18", 24", 36", 48", 60" and 72".

The Model R: Standard Irrrometer for use in row, tree and field crops. Scale is 0 to 100 centibars (kPa).

Model SR



The Model SR: A Model R with a threaded removeable tip.

The Model LT: Has a "Quick-Flo" tip for use in very light (coarse) soils and non-soil planting media where irrigation decisions are made in the very wet (Low Tension) end of the soil moisture spectrum. Scale is 0 to 40 centibars (kPa).

Model LT



The Model MLT: This is a miniature version of the Model LT for use with small containers in greenhouse applications.

Automatic Irrrometers

Model MLT



These instruments are fitted with switches for automating irrigation decision or with transducers for integration with computerized control systems.

The Model RA: This is a Model R with direct switching capabilities. Adjustable selector switch can be set to any desired moisture level. Switch closes past the setting to actuate solenoid valve, time clock or warning light.

Model RA



The Model SRA: This is a Model SR with the same direct switching capabilities.

The Model LTA: This is a Model LT with the same direct switching capabilities.

Model RSU



The Model RSU: This replaces the gauge on any Irrrometer thus Converting the reading to a 4-20mA loop current signal. For example: SR-RSU-12". Calibrations vary with instrument measurement range.

Watermark Sensors



Watermark
Soil Moisture Sensor

The Watermark is a resistance type granular matrix sensor. The resistance across a pair of electrodes imbedded within the granular matrix varies with moisture content. This varied resistance is calibrated against known values and reported as soil water tension, the same value we obtain from an Irrrometer tensiometer reading. Internally installed gypsum is used as a buffering agent to compensate for the effects of varying salinity levels typically found in the irrigated agricultural environment. Watermarks sensors can be read by several different devices.



Watermark Electronic
Meter (30-KTCD-NL)

The Watermark Meter is a solid state alternating current resistance bridge meter for reading Watermark sensors. It is adjustable for soil temperature variations. One meter is required to read an unlimited number of sensors, one at a time. The Meter includes: touch pad operating panel, durable case and field changeable cable assembly. Read from 0 cb (wet) to 199 cb (very dry).

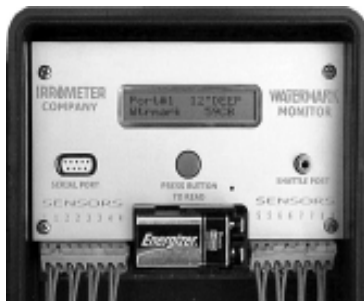

Watermark
Monitor

The Watermark Monitor automatically reads up to eight sensors. The readings can be downloaded to a computer for graphical representation, which makes the changes in soil moisture status easier to identify. Current readings are also displayed in the field for making on the spot scheduling decisions. Several sensor selections are available for each input port. Either Watermark soil moisture sensors, soil temperature sensors, dry contact switch closure sensors, Irrrometer Model RSU tensiometers and other 4-20mA or voltage input sensors can be utilized. Data can be downloaded directly to a computer, via a PDA, via radio or via cellular telemetry.



Watermark Electronic
Module (WEM)

The Watermark Electronic Module (WEM) uses two Watermark sensors placed at varying depths within the root zone. The total tension is measured and averaged to report the overall condition within the root zone. This device typically works in conjunction with a standard 24 VAC irrigation controller. The WEM is in effect a switch which interrupts the common ground connection between the control valves and the controller. The irrigation scheduler selects the appropriate moisture level on the dial of the WEM, and the controller is allowed to only run the irrigation cycles necessary. Truly "automatic" scheduling is provided.

CHOOSING BETWEEN IRROMETERS AND WATERMARKS

SELECTION GUIDELINES

GENERAL

1. Maintenance Requirement - Some maintenance is required with Irrometers, no maintenance with Watermarks
2. Irrometers need to be protected from damage by freezing temperatures, Watermarks do not.
3. Cost - Irrometers are less expensive up to 6 sensors. With more sensors, Watermarks become less costly.
4. Sensitivity/Accuracy - Irrometers react quicker to soil moisture changes than Watermarks and are more accurate and sensitive, especially in the “wet” end (below 25 centibars). Model LT is best suited to these applications, from 5 to 20 centibars.

SPECIFIC

Factors to be considered:

- Soil type
- Crop sensitivity to moisture stress
- Irrigation method being used
- Soil suction thresholds

Model LT - Most sensitivity and accuracy in the low tension range, from 0 to 40 centibars, direct reading method

Model R/SR - Sensitive and accurate through 80 centibars, direct reading method

Watermark - Less sensitive and slower to respond in the wet end, but can go much higher in the dry end, to 199 centibars, indirect reading method.

Soil Type Crop Sensitivity Irrigation Method Soil Suction

Model R/SR	Lighter to Medium Soils	Sensitive to Medium Sensitivity	Drip, Sprinkler, Furrow, Center Pivot	15 to 75 centibars
Model LT	Non-Soil Media, Amended Soils, Coarse Sandy Soils	Very Sensitive Crops	Drip, Trickle, Micro Spray, Capillary	5 to 20 centibars
Watermark	Medium to Heavier Soils	Medium to Drought Tolerant Crops	Drip, Sprinkler, Furrow, Flood, Center Pivot	20 to 200 centibars

Irrrometer installation detail - Orchards

NOTE: Irrrometer placement depth is a function of crop root depth.

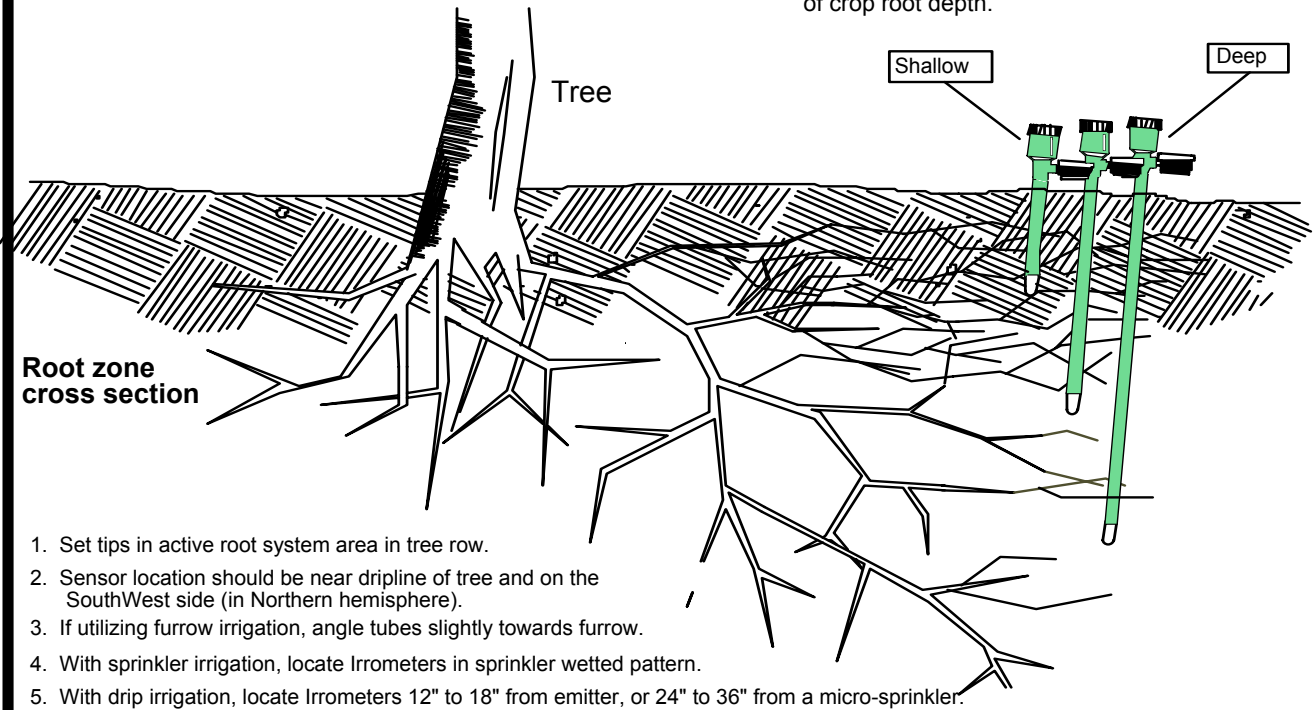

1. Set tips in active root system area in tree row.
2. Sensor location should be near dripline of tree and on the SouthWest side (in Northern hemisphere).
3. If utilizing furrow irrigation, angle tubes slightly towards furrow.
4. With sprinkler irrigation, locate Irrrometers in sprinkler wetted pattern.
5. With drip irrigation, locate Irrrometers 12" to 18" from emitter, or 24" to 36" from a micro-sprinkler.

Irrrometer 1

01/30/02

Irrrometer installation detail - Row Crops

NOTE: Irrrometer placement depth is a function of crop root depth.

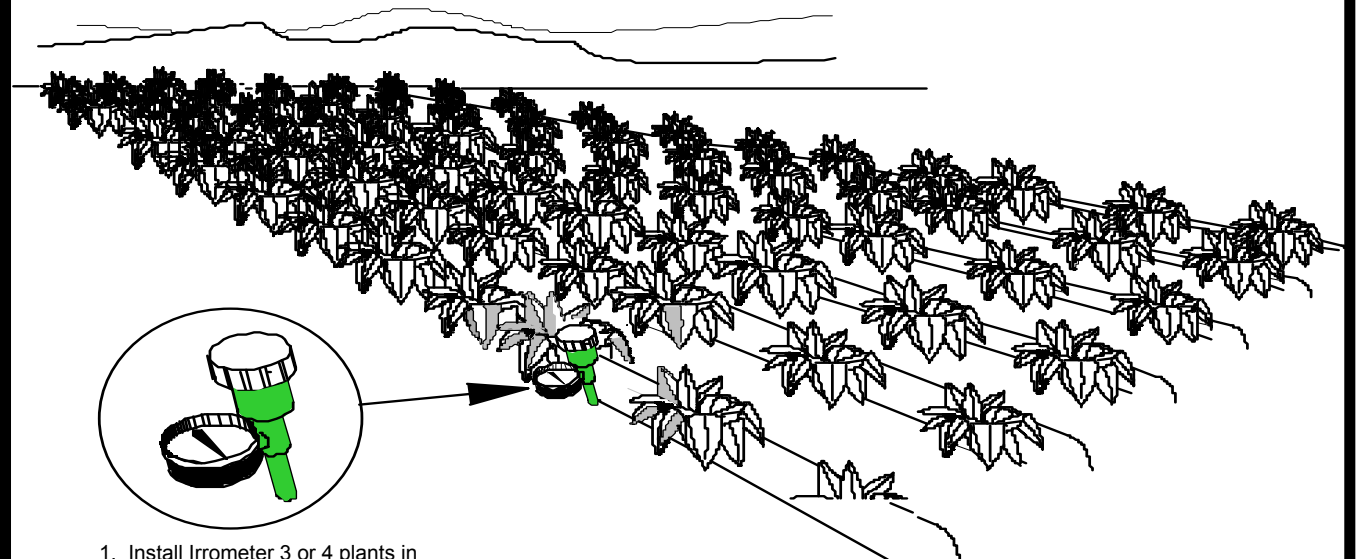

1. Install Irrrometer 3 or 4 plants in from the road to avoid traffic damage.
2. Install instrument at root zone, and in the crop row.
3. On larger irrigation blocks, a monitoring location every 15 to 20 acres is recommended.
4. Use short (shallow) and long (deeper) Irrrometers on 18" or deeper root systems.

Irrrometer 2

01/30/02

Irrrometer Installation detail - Vines on Drip

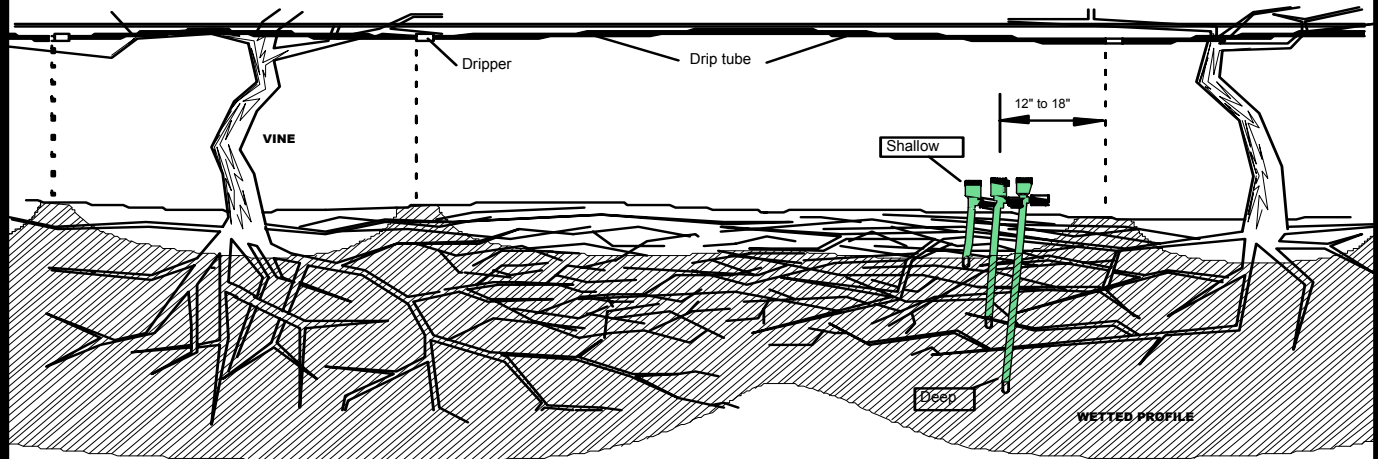

NOTE: Wetted profile could differ from that shown above depending on soil types.

1. Install Irrrometers 3 or 4 vines in from the road to avoid traffic damage.
2. Install instruments in the active root zone in the vine row.
3. On larger irrigation blocks, a monitoring location every 15 to 20 acres is recommended.
4. Use short (shallow) and long (deeper) Irrrometers on 18" or deeper root systems.

NOTE: Irrrometer placement depth is a function of crop root depth.

Irrrometer 3 - Vines on Drip

02/25/02

Irrrometer Installation detail - Vines on Jets or Microsprinklers

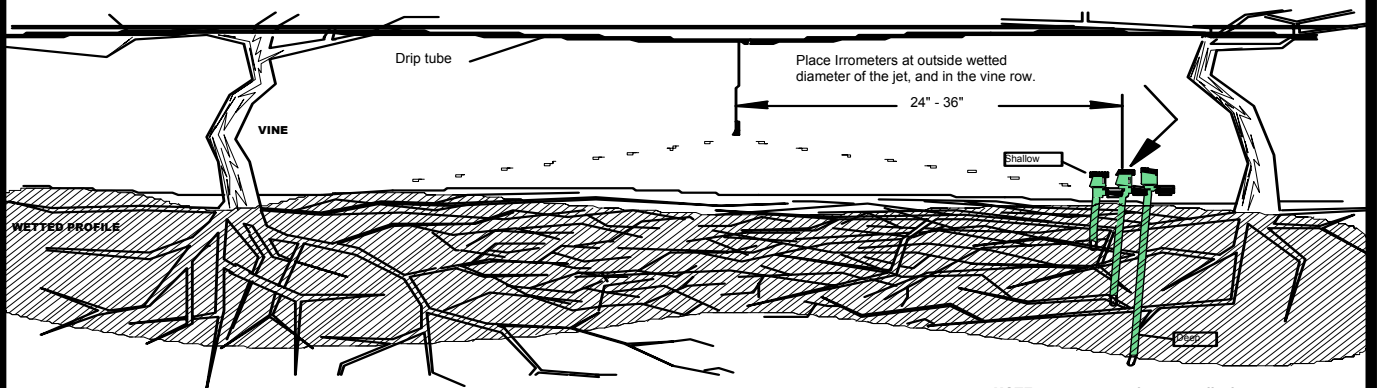

NOTE: Wetted profile could differ from that shown above depending on soil types.

1. Install Irrrometers 3 or 4 vines in from the road to avoid traffic damage.
2. Install instruments in the active root zone in the vine row.
3. On larger irrigation blocks, a monitoring location every 15 to 20 acres is recommended.
4. Use short (shallow) and long (deeper) Irrrometers on 18" or deeper root systems.

NOTE: Irrrometer placement depth is a function of crop root depth.

Irrrometer 4 - Vines on Jets or Microsprinklers

02/25/02

Watermark installation detail - Orchards

NOTE: Watermark placement depth is a function of crop root depth.

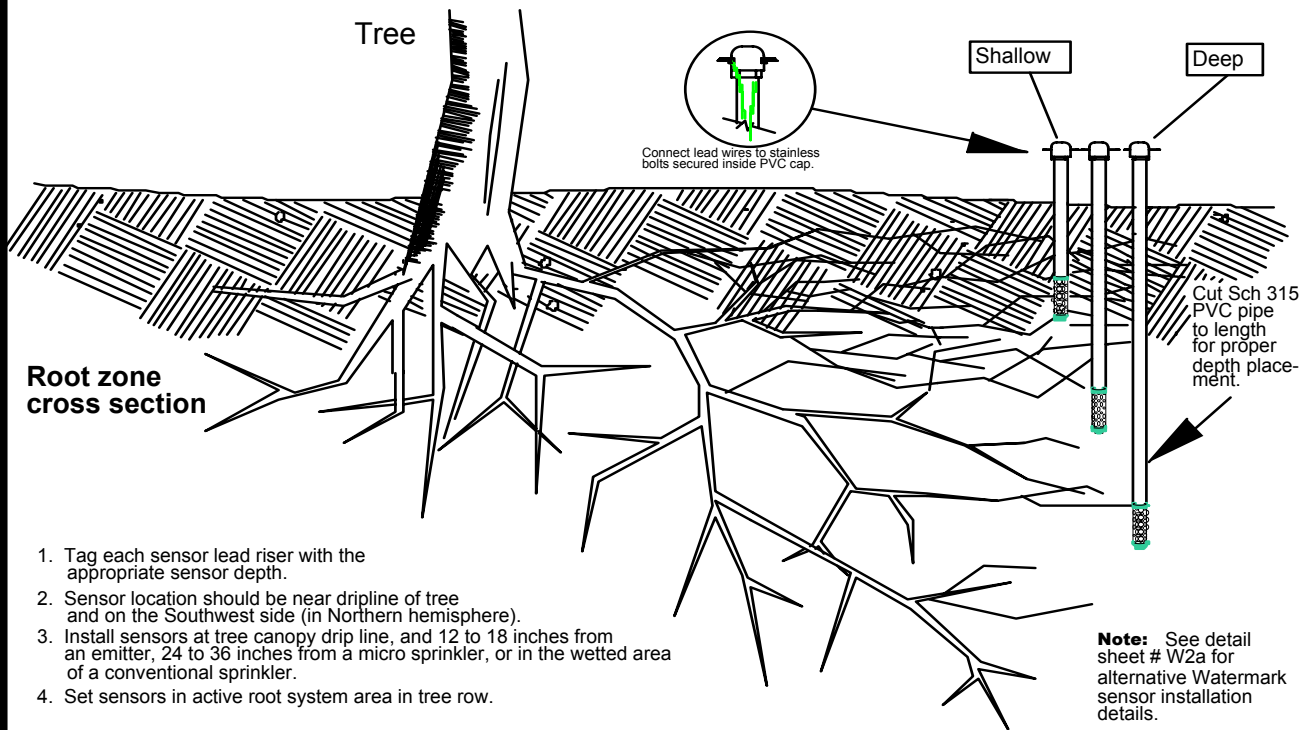

Watermark 1

01/30/02

Watermark installation detail - Row Crops

NOTE: Watermark placement depth is a function of crop root depth.

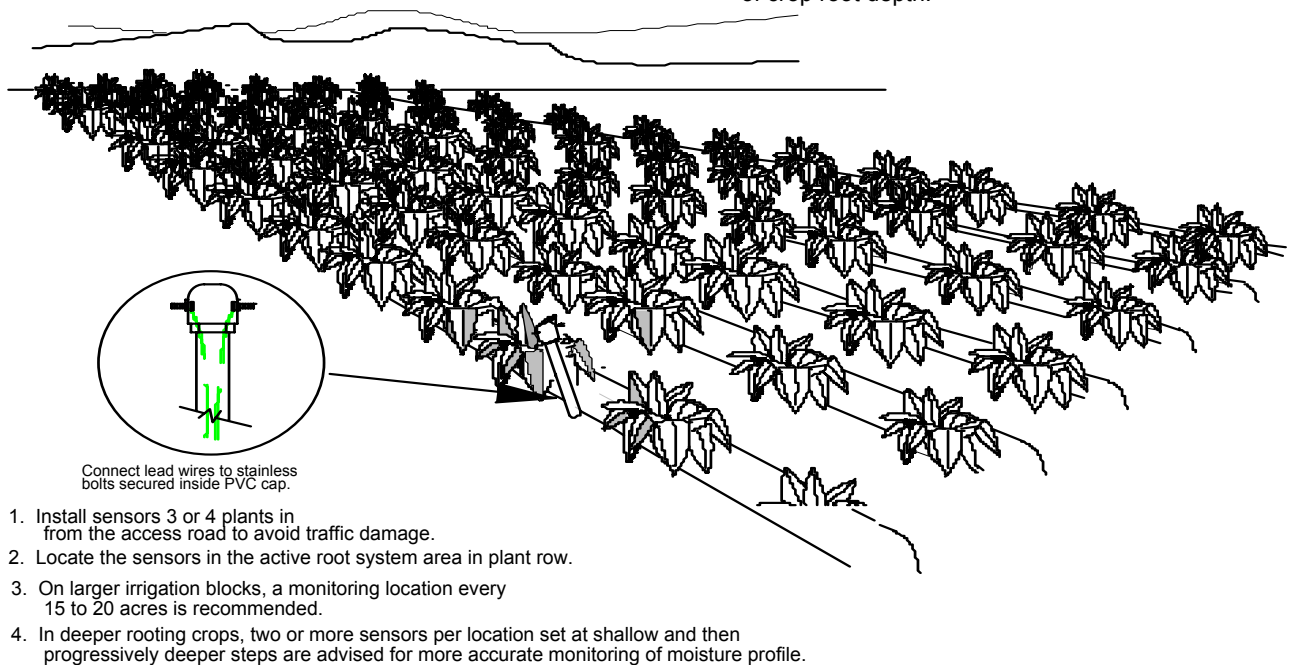

Watermark 2

03/12/02

Watermark Installation detail - Vines on Drip

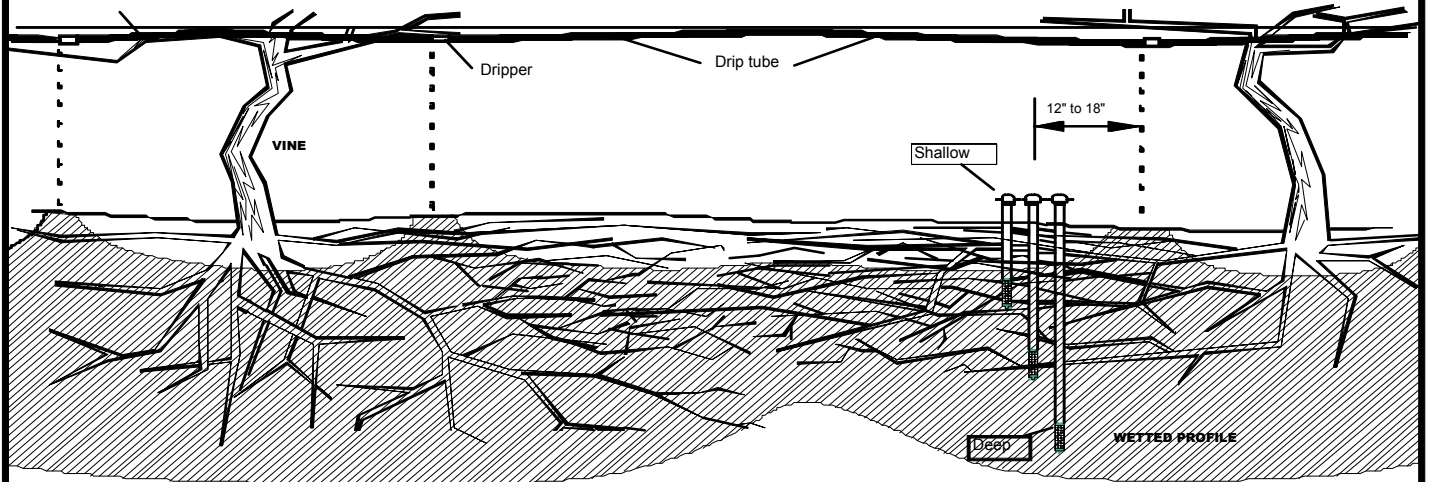

NOTE: Wetted profile could differ from that shown above depending on soil types.

1. Install Watermarks 3 or 4 vines in from the road to avoid traffic damage.
2. Install instruments in the active root zone in the vine row.
3. On larger irrigation blocks, a monitoring location every 15 to 20 acres is recommended.
4. Use short (shallow) and long (deeper) Watermark sensors on 18" or deeper root systems.

NOTE: Watermark placement depth is a function of crop root depth.

Watermark 3 - Vines on Drip

03/07/02

Watermark Installation detail - Vines on Drip

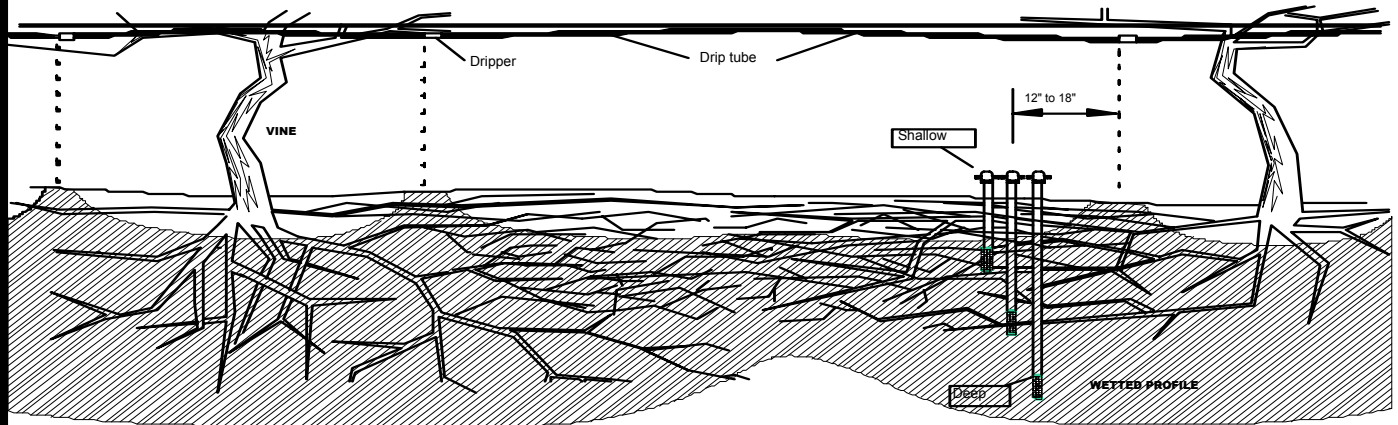

NOTE: Wetted profile could differ from that shown above depending on soil types.

1. Install Watermarks 3 or 4 vines in from the road to avoid traffic damage.
2. Install instruments in the active root zone in the vine row.
3. On larger irrigation blocks, a monitoring location every 15 to 20 acres is recommended.
4. Use short (shallow) and long (deeper) Watermark sensors on 18" or deeper root systems.

NOTE: Watermark placement depth is a function of crop root depth.

Watermark 3 - Vines on Drip

03/07/02

TYPICAL IRROMETER or WATERMARK PLACEMENT - 130 Ac. CENTER PIVOT

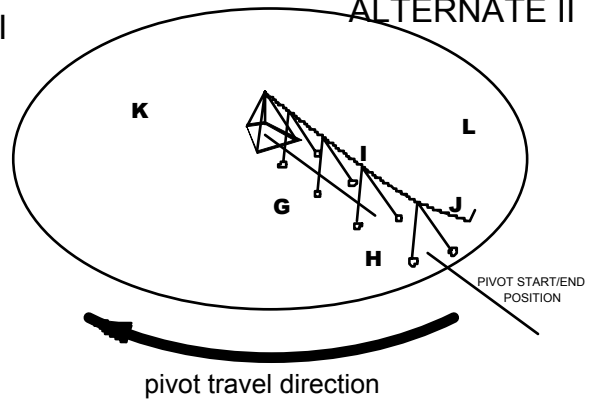
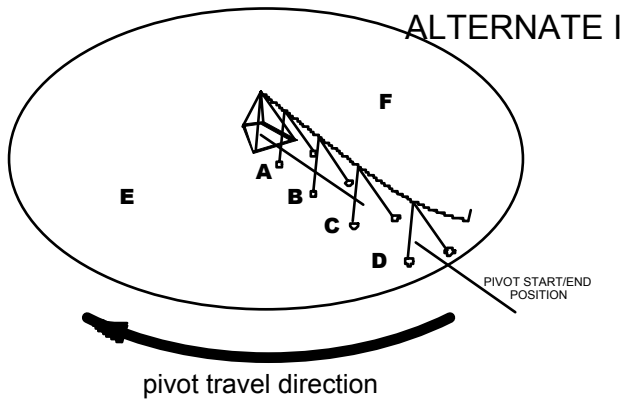

ALWAYS USE TWO (2) IRROMETERS OR WATERMARKS PER LOCATION, ONE SHALLOW AND ONE DEEP.

- A = BETWEEN TOWERS 2 AND 3
- B = BETWEEN TOWERS 4 AND 5
- C = BETWEEN TOWERS 6 AND 7
- D = BETWEEN TOWERS 8 AND 9
- G = BETWEEN TOWERS 3 AND 4 (START POSITION)
- H = BETWEEN TOWERS 7 AND 8 (START POSITION)
- I = BETWEEN TOWERS 3 AND 4 (FINISH POSITION)
- J = BETWEEN TOWERS 7 AND 8 (FINISH POSITION)
- E AND K = "HOT SPOT" - LIGHTEST SOIL - QUICKEST TO DRY
- F AND L = BEST PRODUCTION AREA IN FIELD

Notes:

- Set shallow sensors at approx. 25% of the crop rooting depth.
- Set deep sensors at approx. 75% of the crop rooting depth.
- Sensors near start and finish positions should be a few sprinkler diameters away from the actual start/finish line.

Irrometers or Watermarks on Center Pivot

10/24/05

Greenhouse Application

MLT IN CONTAINER

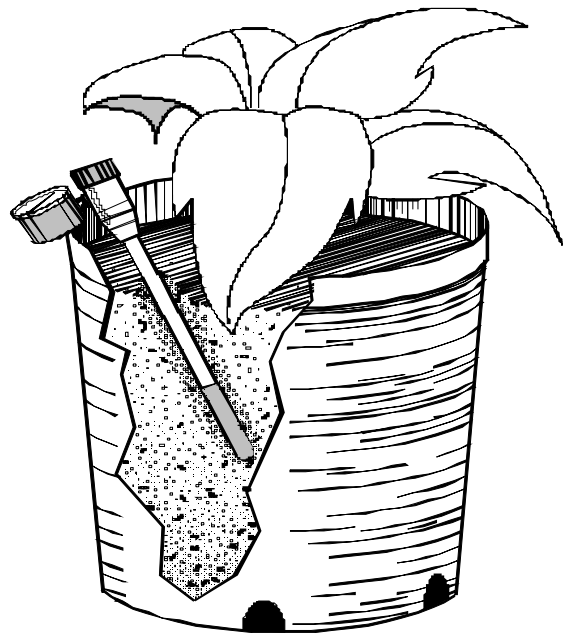

1. Place tip in root mass area, usually halfway down the pot.
2. Angle with gauge downward and resting on container edge for support.
3. Select container in drier area of bench.
4. "Flag" container being monitored for easy identification.

Irrrometer 5 - Irrrometer in Container

10/24/05

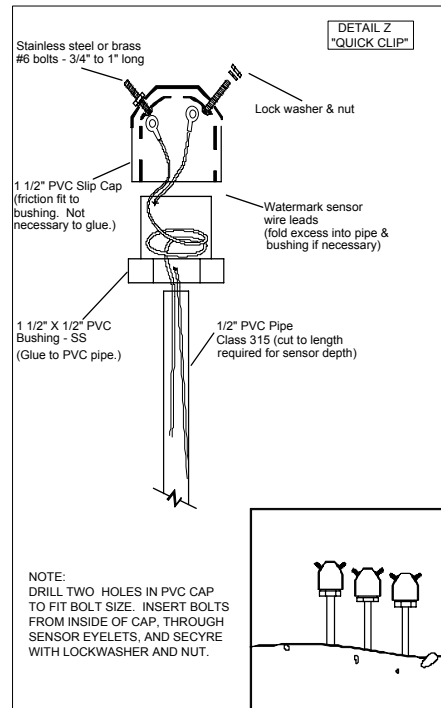
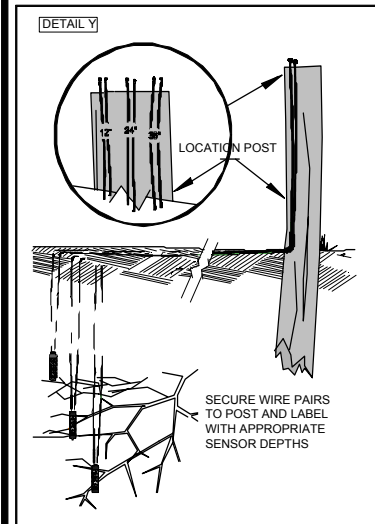
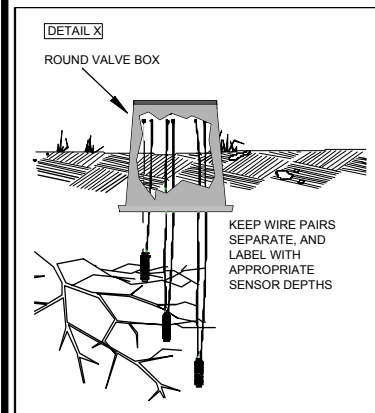

NOTE:
DRILL TWO HOLES IN PVC CAP TO FIT BOLT SIZE. INSERT BOLTS FROM INSIDE OF CAP, THROUGH SENSOR EYELETS, AND SECURE WITH LOCKWASHER AND NUT.

SAMPLE WIRING DETAILS FOR MANUALLY READING WATERMARK SENSORS WITH HANDHELD METER (#30KTCD-NL)

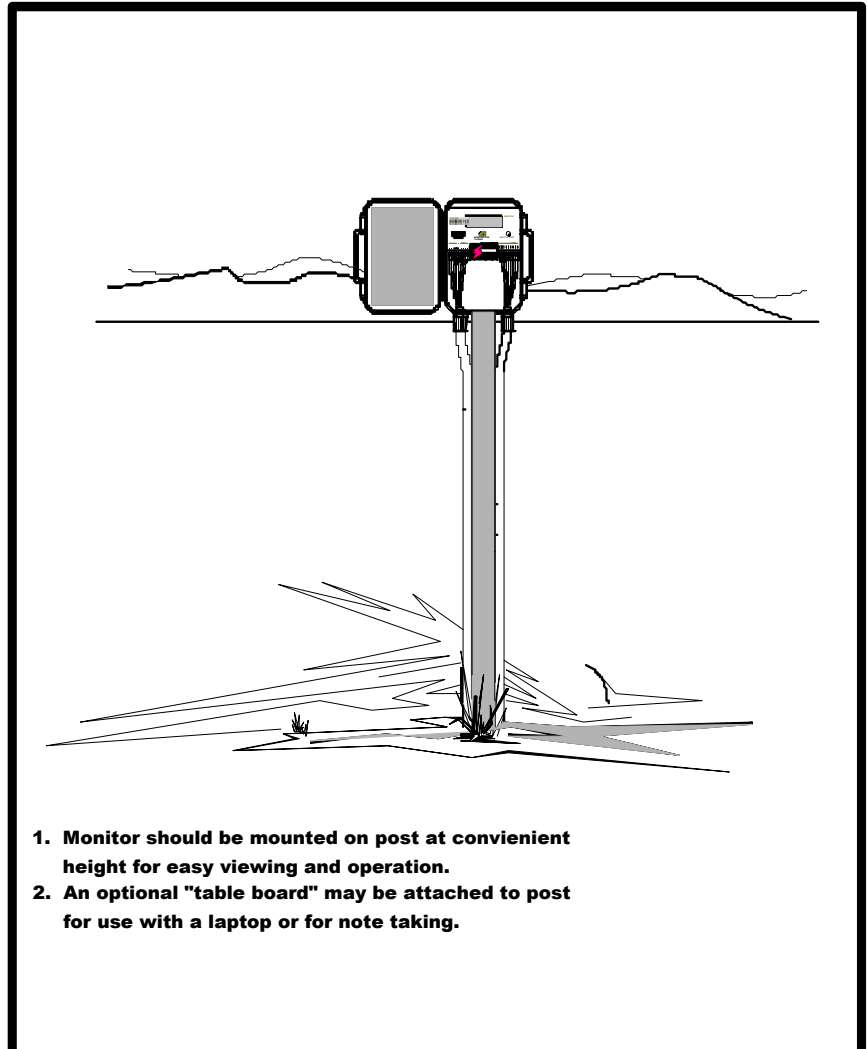

- 1. Monitor should be mounted on post at convenient height for easy viewing and operation.**
- 2. An optional "table board" may be attached to post for use with a laptop or for note taking.**

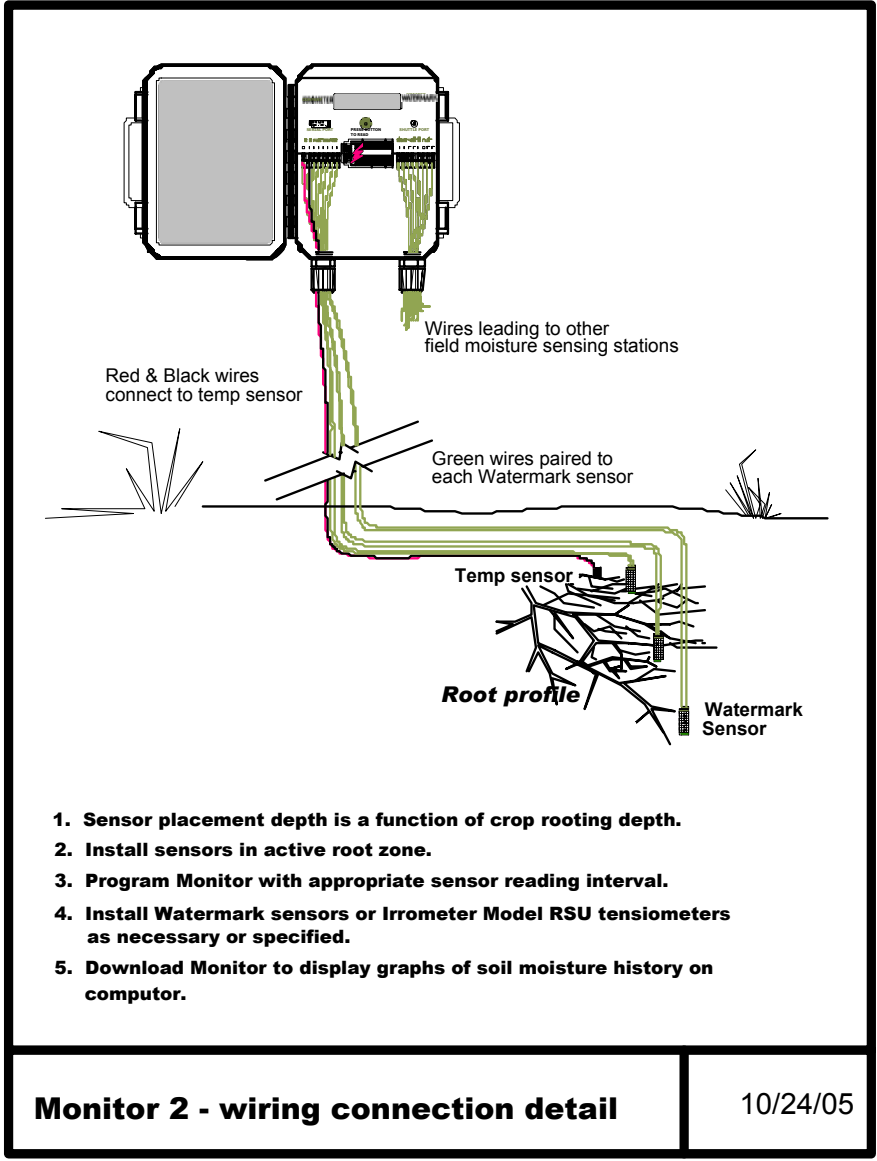

Monitor 2 - wiring connection detail

10/24/05

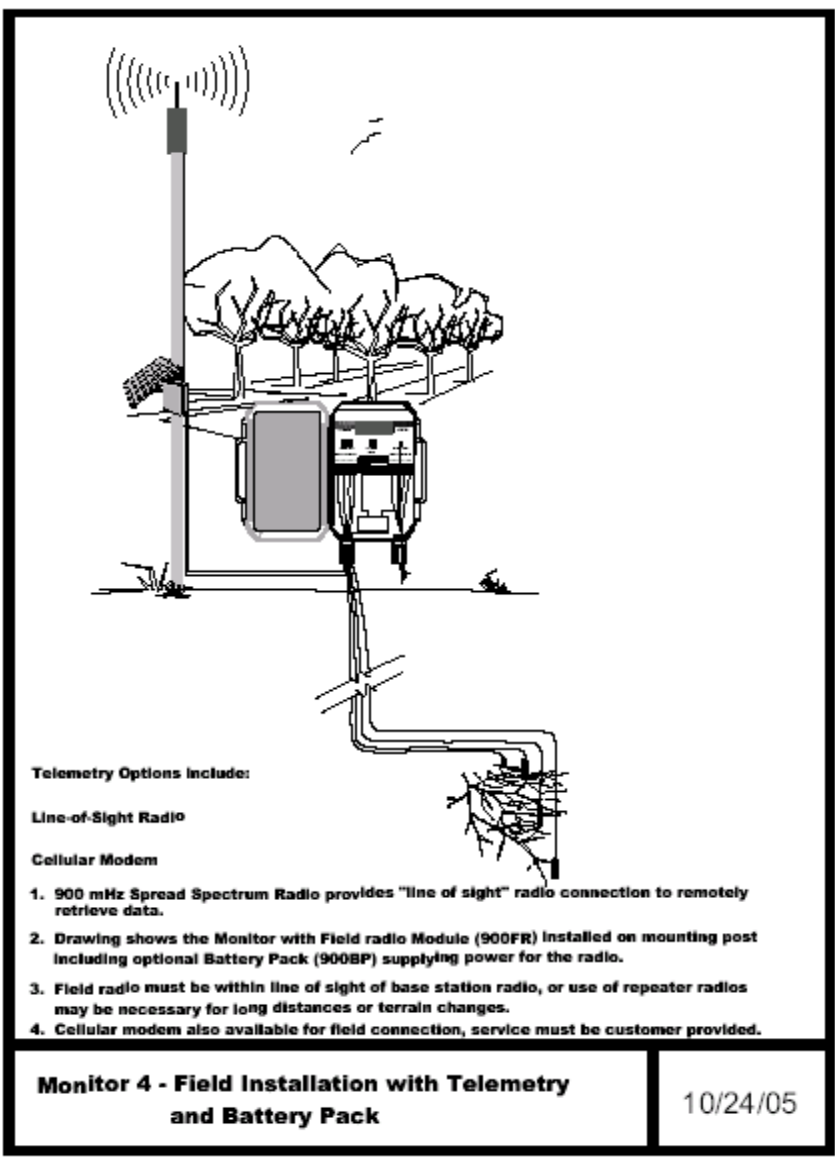

Monitor 4 - Field Installation with Telemetry and Battery Pack

10/24/05

Soil Solution Access Tubes

...for Nutrient Management

Irrrometer Soil Solution Access Tubes, SSAT, are used for monitoring the effectiveness of "fertigation" regimes. The process of suction extract analysis uses these tubes to extract actual soil water samples, which can then be analyzed for elements commonly used in fertigation and chemigation. These SSATs, or suction lysimeters, are typically used to obtain samples for the determination of such things as nitrate concentration, EC or salinity levels. Please note: Use for measuring pH is limited, but can be performed utilizing additional procedures, please consult factory for details.

In practice, after the fertigated water has been applied, a vacuum is drawn on the tube with the syringe or a hand vacuum pump, for lengths longer than 12 inches (30 cm). After sufficient time has elapsed for soil water to be drawn into the tube, the collected soil water solution is extracted from the tube with the syringe. Analysis is typically done in the field with portable devices, such as test kits or meters, or sent to a laboratory.

1. Insert SSAT tip into active root zone at the depth where the sample is to be extracted.
2. Connect syringe or pump to suction line tubing, making sure finger clamp is open.
3. Pull a vacuum, then pinch finger clamp closed.

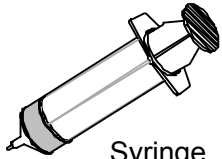

Syringe
(Sample Extractor)

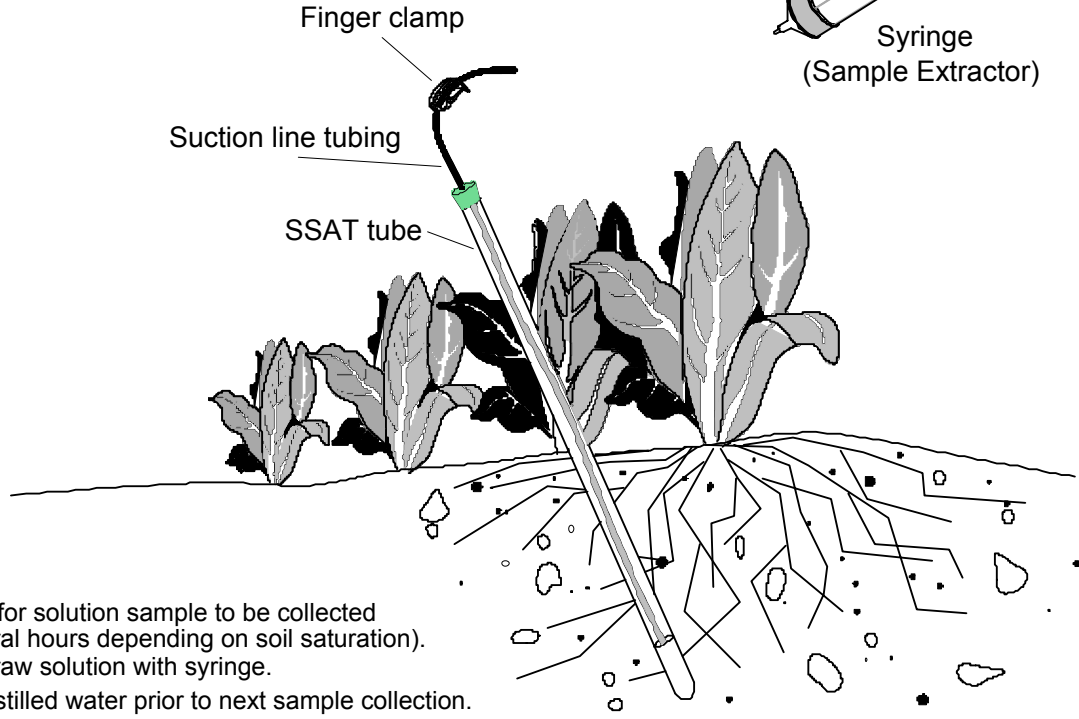

Finger clamp

Suction line tubing

SSAT tube

4. Allow adequate time for solution sample to be collected (this could take several hours depending on soil saturation). Open clamp to withdraw solution with syringe.
5. Rinse syringe with distilled water prior to next sample collection.
6. Placement of SSAT's at moisture sensor location helps validate soil saturation status.
7. Use of a longer SSAT provides greater vacuum capacity, thus making sample collection more efficient. For example, using an 18" tube at 8" sampling depth.

Irrrometer Pressure Gauges

Irrrometer offers pressure gauges designed for the demanding conditions of irrigation service.

Hermetically Sealed for long life and corrosion resistance to provide years of trouble-free service in the toughest field conditions.

Liquid-Filled for applications where vibration is a problem.

Switching Pressure Gauges are also available for applications where a pressure activated switch closure is needed.

FOR IRRROMETER
TECHNICAL SUPPORT
CALL (951) 689-1701

WATER TIGHT
RUST PROOF
DUST PROOF
SHATTER PROOF FACE

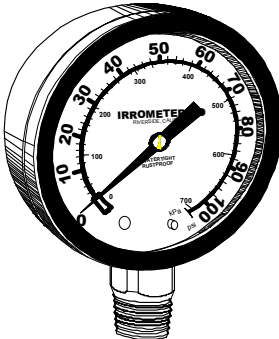

HERMETICALLY SEALED 2" PRESSURE GAUGE
PRESSURE RANGE(S):

- ___ 0-15 PSI
- ___ 0-30 PSI
- ___ 0-60 PSI
- ___ 0-100 PSI
- ___ 0-200 PSI
- ___ 0-400 PSI

ALL GAUGES ARE DUAL SCALE WITH PSI AND kPa
ASME B40.1 GRADE B COMMERCIAL SERIES
1/4" NPT BRASS BOTTOM CONNECTION
INTERNAL COMPONENTS:
BRASS WITH NYLON GEAR AND PHOSPHORUS BRONZE BOURDON TUBE
CLEAR BUTYRATE OUTER FACE AND POLYCARBONATE INTERNAL FACE
THERMO PLASTIC RUBBER (TPR) COVER

THIS DURABLE, SPECIALLY CONSTRUCTED HERMETICALLY SEALED GAUGE IS DESIGNED TO GREATLY LENGTHEN SERVICE LIFE

AVAILABLE WITH FACTORY INSTALLED INTERNAL SNUBBER TO HELP ABSORB SURGES (SNUBBER IS REMOVEABLE FOR CLEANING)
___ S

12 Irrrometer Sealed Pressure Gauge

FOR IRRROMETER
TECHNICAL SUPPORT
CALL (951) 689-1701

STAINLESS STEEL COVER
LIQUID FILLED

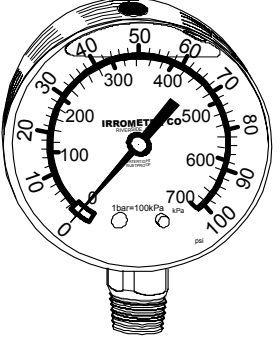

LIQUID FILLED 2 1/2" PRESSURE GAUGE
PRESSURE RANGE(S):

- ___ 0-60 PSI
- ___ 0-100 PSI
- ___ 0-200 PSI
- ___ 0-400 PSI

ALL GAUGES ARE DUAL SCALE WITH PSI AND kPa
ANSI B40.1 GRADE B COMMERCIAL SERIES
1/4" NPT BRASS BOTTOM CONNECTION
INTERNAL COMPONENTS:
BRASS WITH NYLON GEAR AND PHOSPHORUS BRONZE BOURDON TUBE
304 STAINLESS STEEL CASE WITH BUNA-N VENT PLUG
POLYCARBONATE FACE
GLYCERIN FILLING (0-150° F AMBIENT)

THIS GAUGE PROVIDES SUPERIOR PERFORMANCE IN APPLICATIONS WHERE VIBRATION, PULSATION, MECHANICAL SHOCK AND PRESSURE SPIKES ARE COMMON.

AVAILABLE WITH FACTORY INSTALLED INTERNAL SNUBBER TO HELP ABSORB SURGES (SNUBBER IS REMOVEABLE FOR CLEANING)
___ S

13 Irrrometer Liquid Filled Pressure Gauge

IRROMETER

...simple tools for optimizing irrigation, worldwide.

***For information on precision irrigation, contact us on
the web at <http://www.irrometer.com>***

Telephone: (951) 682-9505

FAX : (951) 682-9501

E-mail: sales@irrometer.com

IRROMETER COMPANY

1425 Palmyrita Ave
Riverside, CA 92507

